

CORNELL
Innovative door solutions.®

SmokeShield™ Elevator

Section 1 – Table of Contents





Section 2 – Safety Check List	2
Section 3 – Freight Receiving	3
Section 4 – Pre-installation	4
Section 5 – Installation	5
Section 6 – Maintenance Schedule	16

Section 2 – Safety Check List

Rolling doors are large, movable objects. They move with the help of electric motors or manual operators (chain, crank, push up, etc), and most have springs under high tension. These items and their components can cause injury. In order to avoid injury to yourself and others, please follow the instructions in this manual.

- **Review the potential hazards and preventative measures listed below:**

Table 2.1 - Potential Hazards and Preventative Measures

Potential Hazard		Preventative Measure
	 WARNING Electrical shock.	<ul style="list-style-type: none"> • Make sure electrical operator is properly grounded. • Turn off source power completely prior to servicing the motor. • Make sure wires are clear of any moving or potentially moving parts. • Avoid pinching wires when installing the motor cover.
	 WARNING Pinched by moving components.	<ul style="list-style-type: none"> • Make sure the motor is turned off and unplugged before working with moving parts such as roller chain and sprockets, drop-out mechanisms, adjusting wheels, etc. • Locate the possible pinch-points of the unit (Drive chain, coil area, bottom bar, etc.) Do not operate the door while someone is near these areas.

- **Check the following during installation and before leaving the job site:**
 - a. If the unit has tension springs, be sure the proper amount of tension is applied to the torsion springs, in order to properly counterbalance the weight of the curtain.
 - b. Securely fasten the tension adjusting wheel in place with the appropriate hardware provided.
 - c. Check that the keys and/or cotter pins have been set in place and fit properly at all sprockets or gears.
 - d. Check that the setscrews in each sprocket or gear (one over the key and one offset from the key) have been tightened properly.
 - e. Check all fasteners holding the unit to the building structures.
 - f. Check all fasteners used to assemble the components of the unit together.
 - g. Instruct owner or representative in the proper method of operating the door.

Section 3 – Freight Receiving

- **Upon delivery, check condition of components for damage.**
- **If damage occurred in transit, the installation should not proceed without authorization.**

NOTICE

If the installation proceeds, neither the carrier nor the manufacturer will assume responsibility for replacing the damaged material.

- **If the installation is stopped due to damage, do the following:**
 1. Take pictures of the damage.
 2. Do not move material from point of delivery to other premises once the damaged components are discovered.
 3. Do not unpack, if the damage is visible prior to removing packaging, until an inspection is made.
 4. If the damage is found while removing contents from packaging, the packaging material must be saved until inspection is made.
 5. Container and packaging should be retained by consignee until inspection is made.
 6. Have components inspected by carrier's representative within 15 days from date of delivery.
 7. Consignee must obtain a copy of the Inspection Report.
- **Returning damaged components:**
 1. Obtain permission from carrier to return.
 2. Route the return shipment via the identical carrier(s) involved in the original shipment.
 3. Notify the manufacturer when shipment is returned to manufacture plant.
- **Verify that all components have arrived. Look for the following:**
 1. Job construction drawings featuring different views (elevation, section, plan, etc.)
 2. (2) Wall Guides, (2) Face Guides, and any Additional Guide Packoff Pieces if required (see construction drawing for details)
 3. Headbox Assembly (includes Shaft Assembly, Mounting Plate, Brackets, Hood Assembly, Curtain Assembly, Spring Assembly, and Motor). Will be shipped assembled.
 4. Control Box and Control Box Mounting Hardware (shipped loose)
 5. Mounting Hardware (shipped loose)
 6. Installation Template (shipped loose)
 7. Verify material/finish/color of components matches what is listed on the job construction drawings and/or what was ordered.
- **If the delivery is incomplete:**
 1. Make note on delivery receipt.
 2. Note should be verified by driver's signature.
 3. Notify carrier and manufacturer.

Section 4- Pre-Installation

- **Read entire instruction manual thoroughly. The manufacturer will not be held responsible for any charges incurred due to improperly installed components.**
 - a. Only trained door systems technicians should perform installation, maintenance, etc.
 - b. Each unit comes with an individual item number. If the job contains multiple units, be sure to locate all the components for each item and separate each.

⚠WARNING

Do not interchange parts from one door to another.

- c. Find the job construction drawings for the unit being installed and check the dimensions of the opening against those on the drawings. See **Figure 4.1** below.
 - d. If the opening dimensions differ from those on the drawings, **do not proceed**, check with distributor/manufacturer to be sure the correct door is being installed.
 - e. If the Guides are being installed adjacent to or over the elevator frame, ensure the frame is plumb.
- **Work Area:**
 - a. The key to a smooth installation is a clean and well-prepared work environment. Once the components have been inspected and the job construction drawings have been reviewed; lay out the components in the order of installation.
 - b. The opening for the door should be cleaned and inspected for rough surfaces and construction debris.
 - c. Lastly the mounting hardware supplied with the door should correspond with the surface and construction features of the opening.

Figure 4.1 - Opening Dimensions and Designations

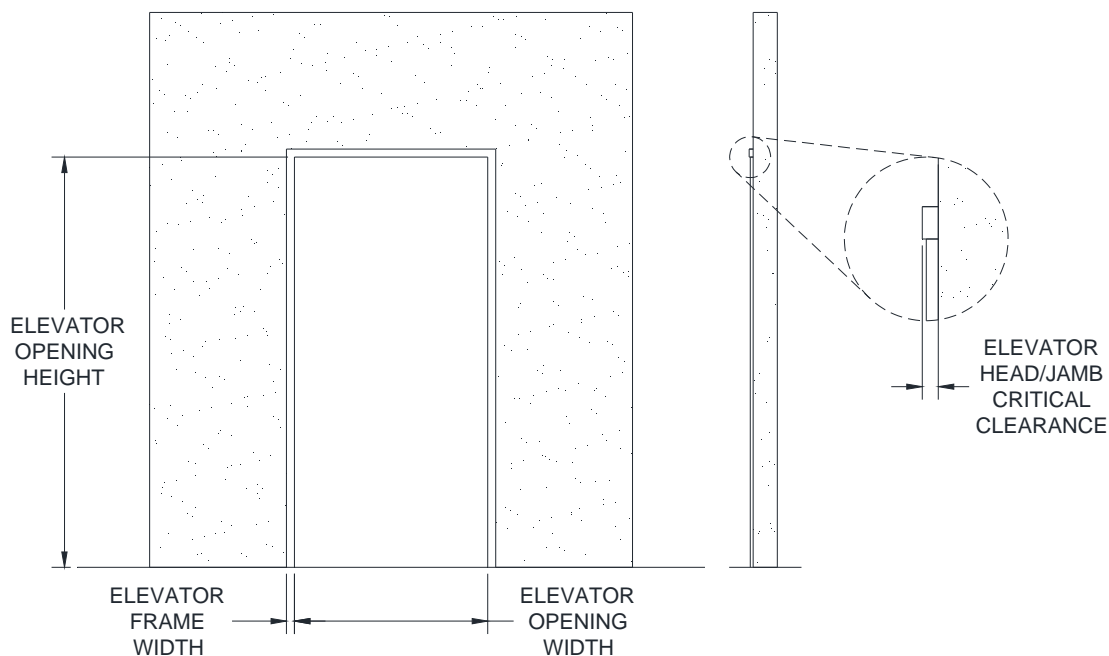

Section 5 - Installation

1. Locate the LH and RH Wall Guides, as well as the #10 wall fasteners provided with the unit. Position the guides as shown in the provided construction drawings.

Figure 5.1 - Wall Guides

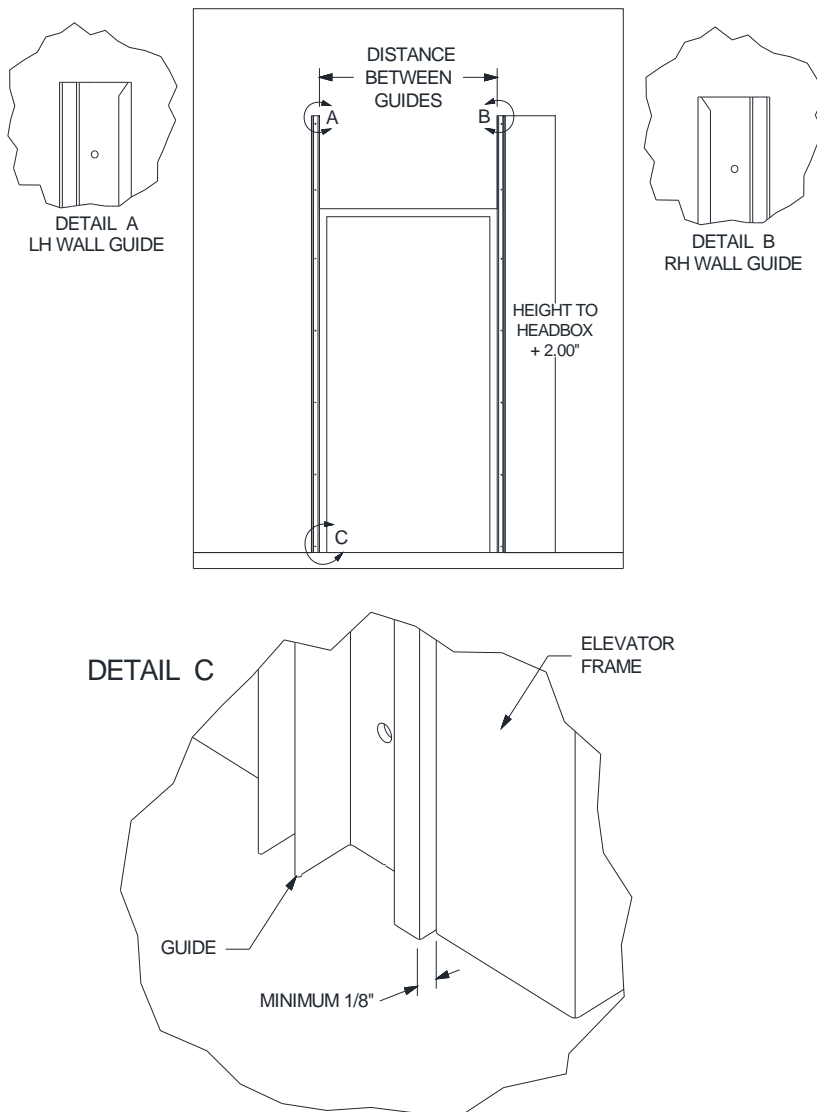

2. Check the following:
 - a. The guides are plumb.
 - b. The Distance Between Guides matches that shown on the construction drawings, and is consistent throughout the height of the guides.
 - c. The top edge of the Wall Guides are level with each other, and match the Height to Headbox dimension shown on the construction drawings +2.00\".
 - d. If the Guides are mounting up against or on top of an elevator frame, ensure that they fit as shown in the construction drawings.
 - e. The Wall Guide clears any protrusion from the wall (i.e. elevator frame) by at least 1/8\".
 - f. Fasten the Wall Guides to the wall using the provided #10 fasteners using the predrilled holes.

Section 5 - Installation

3. Position the Installation Template flush against the RH guide as shown and mark the hole location. Flip the template and do the same for the LH side. Do not drill holes or install fasteners yet.

Figure 5.3 – Marking Wall Fastener Locations

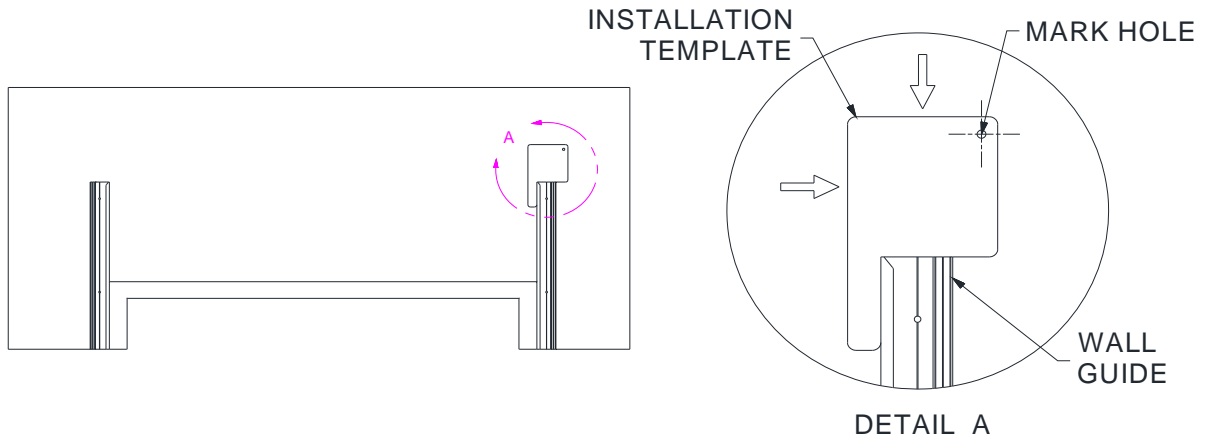

4. Before drilling, measure the center-to-center distance of the marks. This measurement should equal the Distance Between Guides measurement shown on the construction drawings +6.00" (+/-1/16"). This will ensure that the Headbox mounts properly. If this is not the case, double check the Distance Between Guides is correct and adjust if necessary.

Figure 5.4 – Measuring Fastener Location Distance

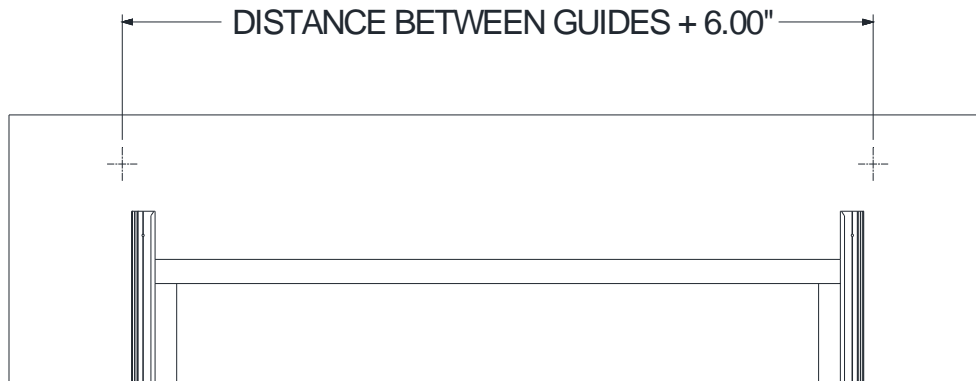

Section 5 - Installation

5. Install #12 Flange Head Tapping screws at each hole location as shown. Leave the head of each fastener protruding from the wall at least 3/16".

Figure 5.5 – Installing Wall Fasteners

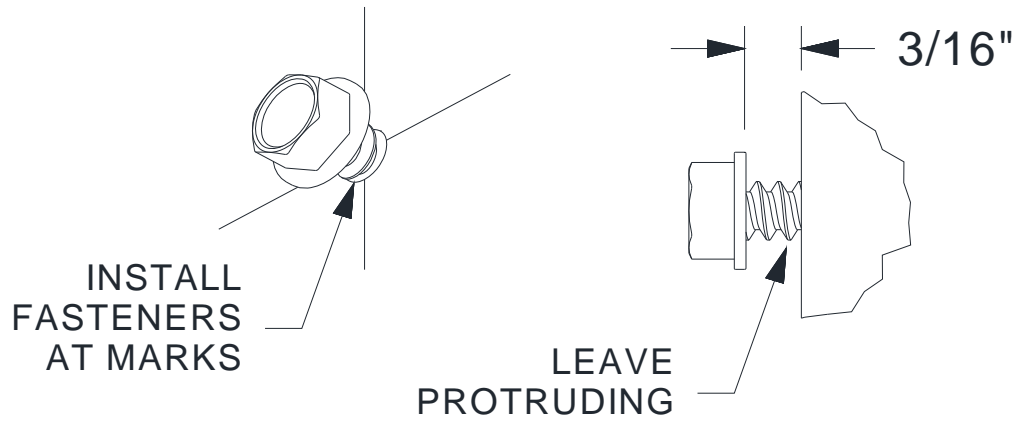

6. Locate the Headbox Assembly. Remove the Hood Cover by removing the #10 fasteners as shown.

Figure 5.6 – Removing Hood Cover

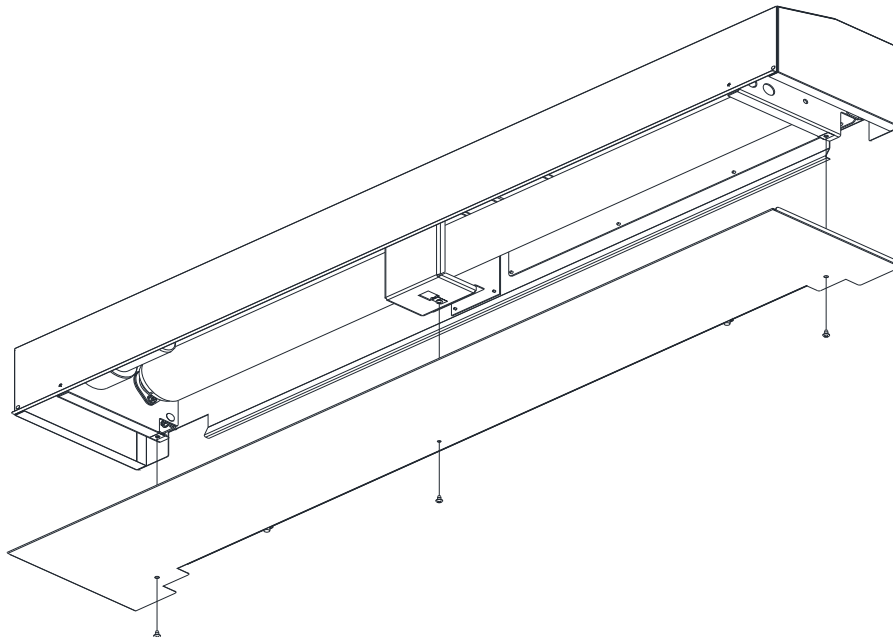

7. Remove the Hood by removing the #10 fasteners.

Figure 5.6 – Removing Hood

Section 5 - Installation

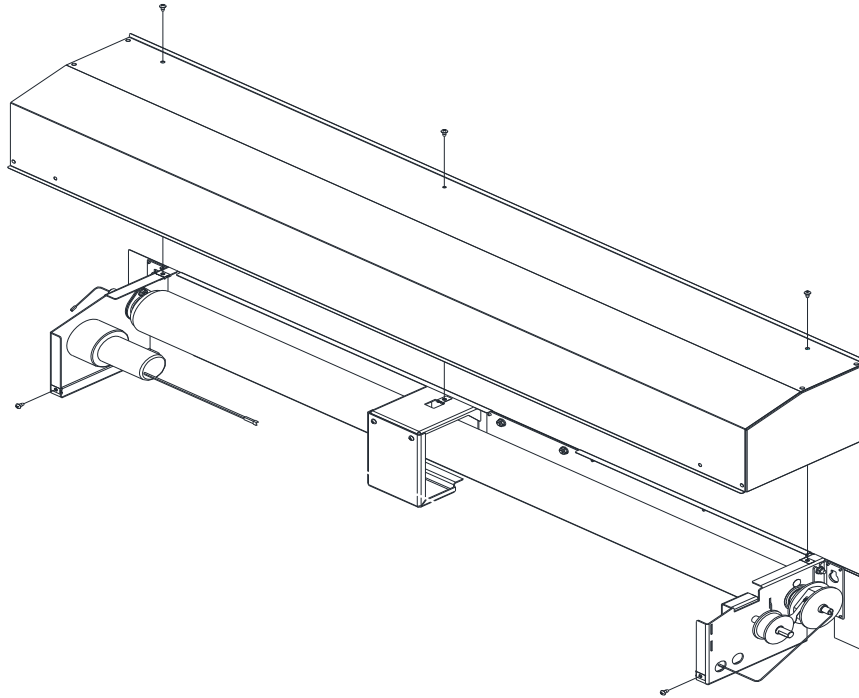

8. Safely Lift the Shaft Assembly and hang it by placing the Mounting Plate keyholes on the preinstalled #12 flange head fasteners.
9. Ensure the Shaft Assembly is level. Tighten the preinstalled #12 fasteners and install the remaining #12 fasteners.

Figure 5.9 – Installing Headbox

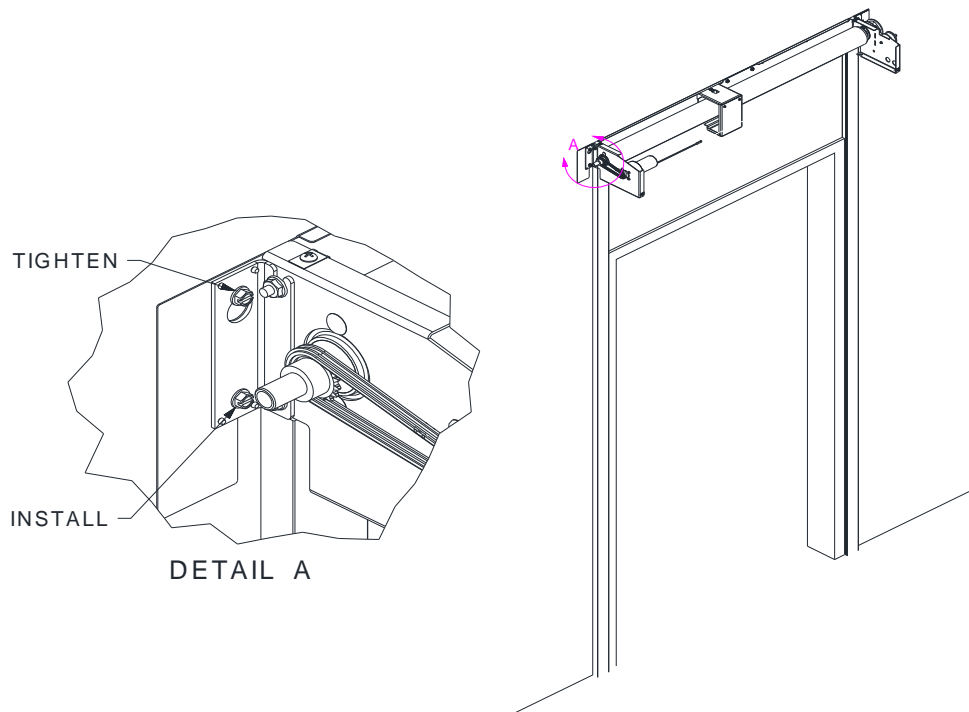

Section 5 - Installation

10. Install the provided #10 self-drilling screws through the precut slots at each stud locations near the top edge of the Mounting Plate. Take care not to damage the curtain. A drill extension may be required for this step.

Figure 5.10 – Mounting Plate Wall Fasteners

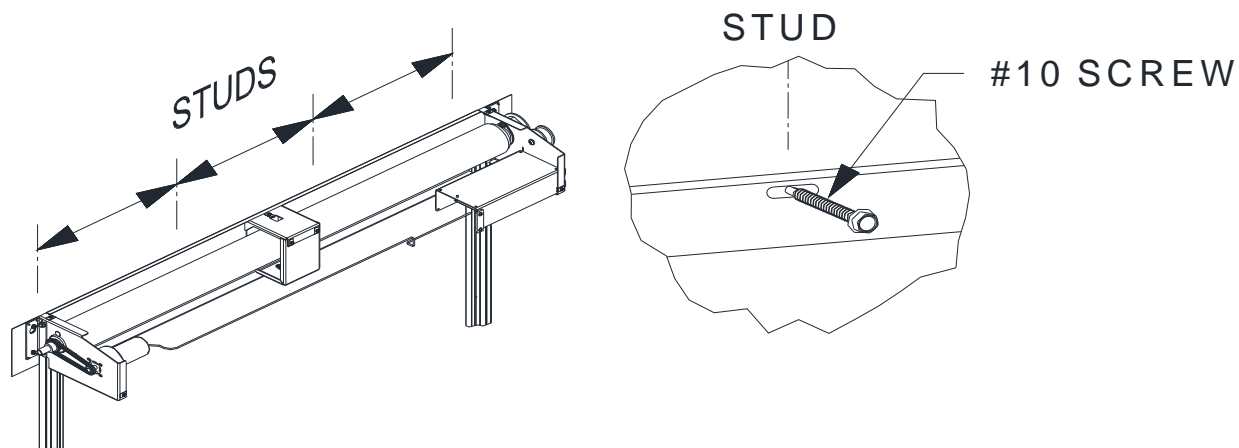

11. If the Control Box is not preinstalled in the Headbox, locate the Control Box, Battery, and Support Bracket. Install the Support Bracket onto the 1/4"-20 Studs as shown.

Figure 5.11 – Control Box Support Bracket (if required)

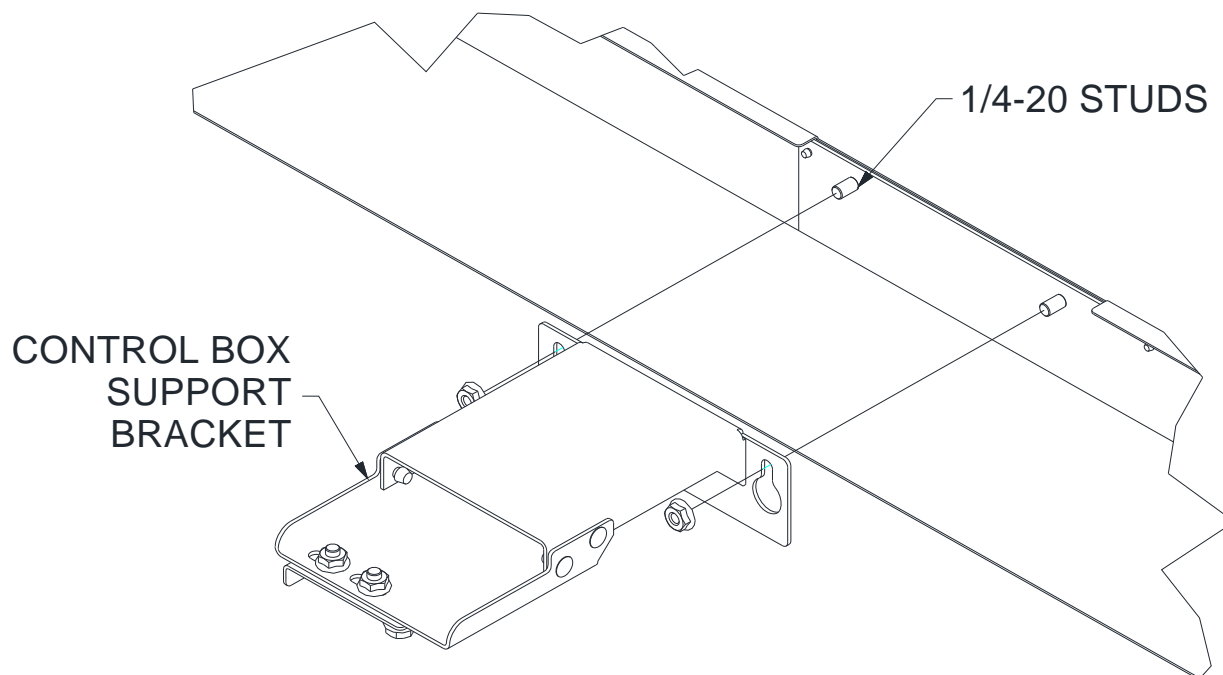

Section 5 - Installation

12. Install the Battery into the Control Box. Install the Control Box onto the RH Bracket by inserting the "J" clip and upper bracket clip into the slots (as shown). Lift the opposite end of the Control Box to the Support Bracket. Insert the downward facing stud through the keyhole on the control box. Slide the Tab such that the nut can be tightened on the narrow section of the keyhole. Tighten the 1/4"-20 fasteners on the upper side of the Support Bracket.

Note: If the unit is being mounted above the ceiling, the control board may be mounted facing forward to be accessed through a removable panel. This mounting arrangement is illustrated in Figure 5.11b.

Figure 5.12a – Installing Standard Control Box

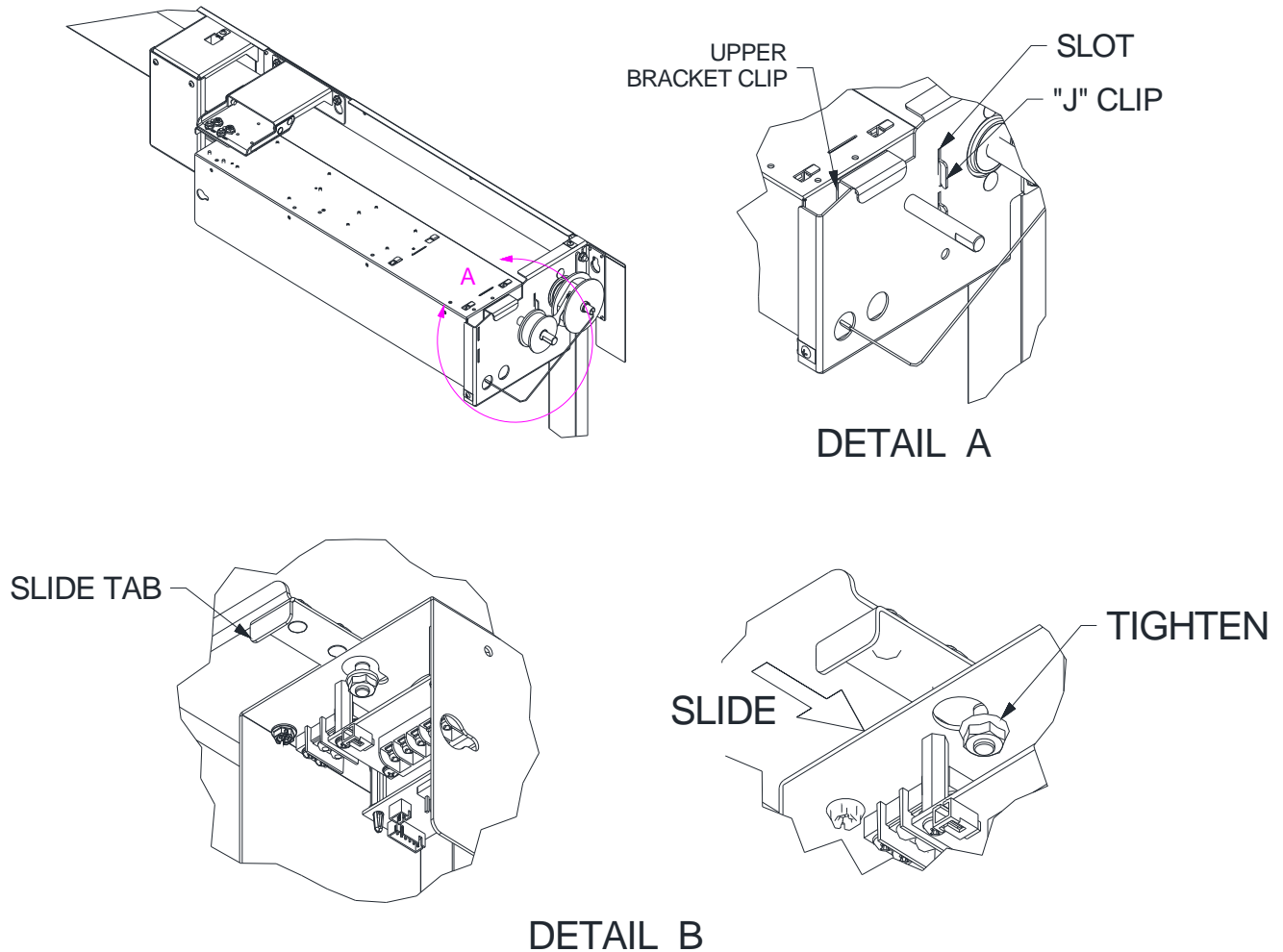

Section 5 - Installation

Figure 5.12b – Installing Upper Access Control Box

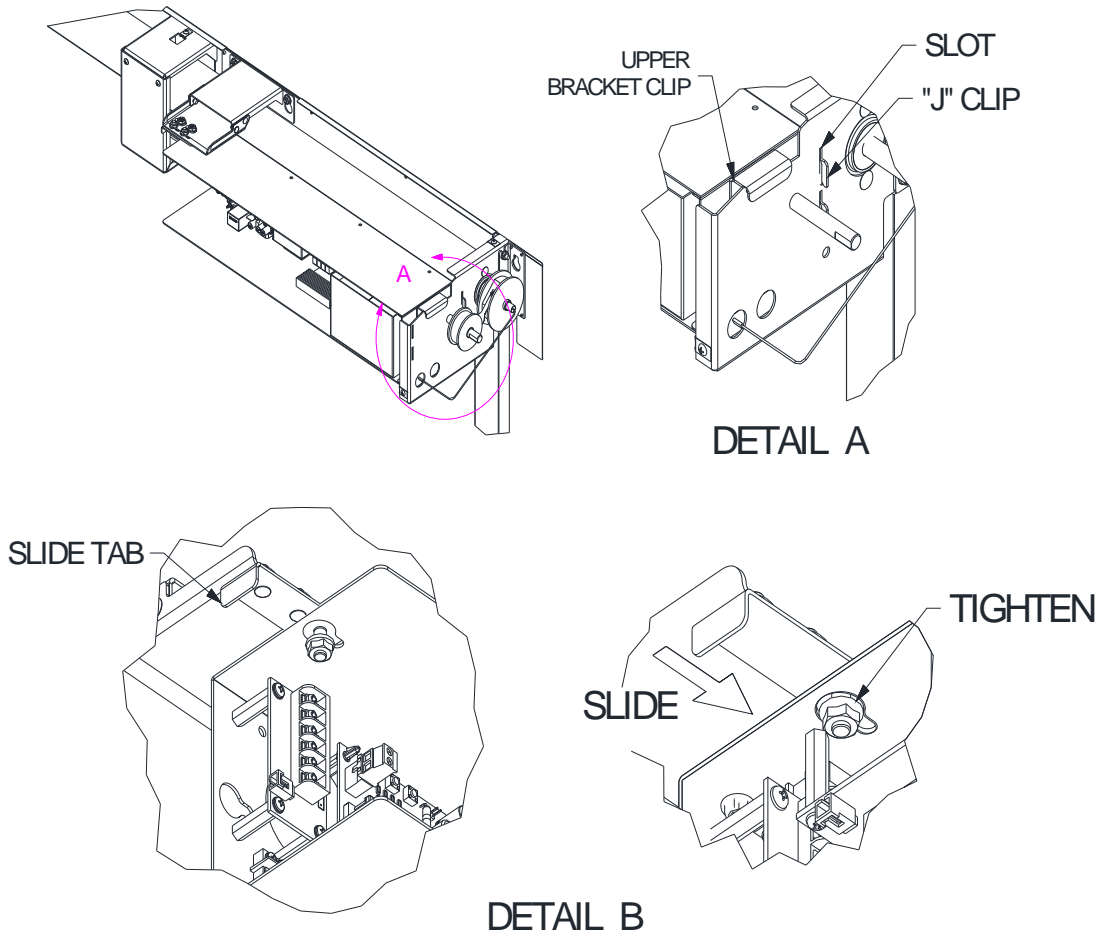

13. Connect the Motor and Egress Switch wires into the Control Box as detailed in the provided Motor Instructions. Secure any loose wires using the provided cable ties.

Note: Secure any loose wires using the provided cable ties. Ensure that all wires are routed away from the spring so that they do not tangle during operation.

14. Install the Hood.

Figure 5.14 – Installing Hood

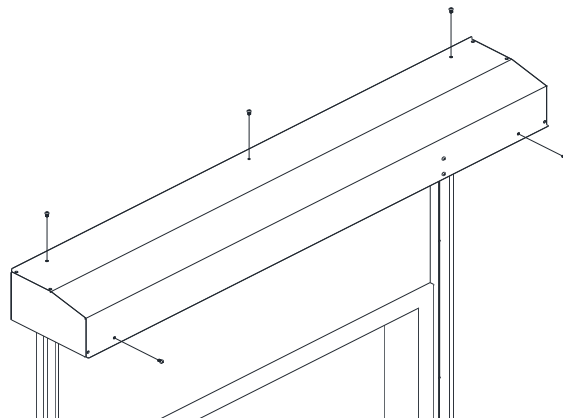

Section 5 - Installation

15. Locate the LH and RH Face Guides.
16. Position the Face Guide onto the Wall Guides as shown.
17. A non-marking rubber mallet can be used to snap the Face Guides onto the Wall Guides. Careful to only strike the Guides in the area detailed in Figures 5.18 and 5.19 in order to not damage the Guides.
18. Work from the bottom up, ensuring the Guides are fully snapped together before moving on.

Figure 5.17 – Strike Method

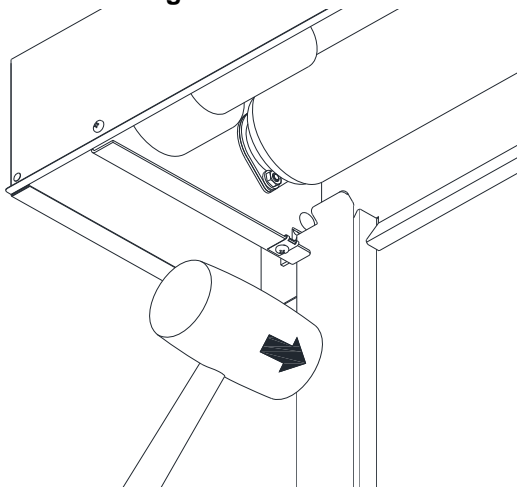

Figure 5.16 – Guide Positioning/Strike Area

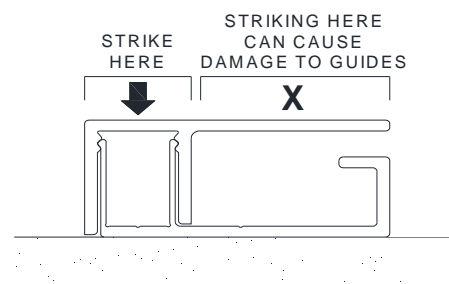
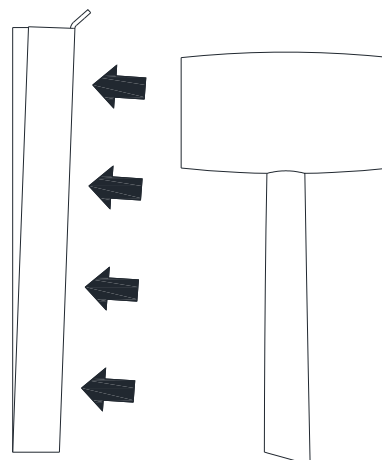
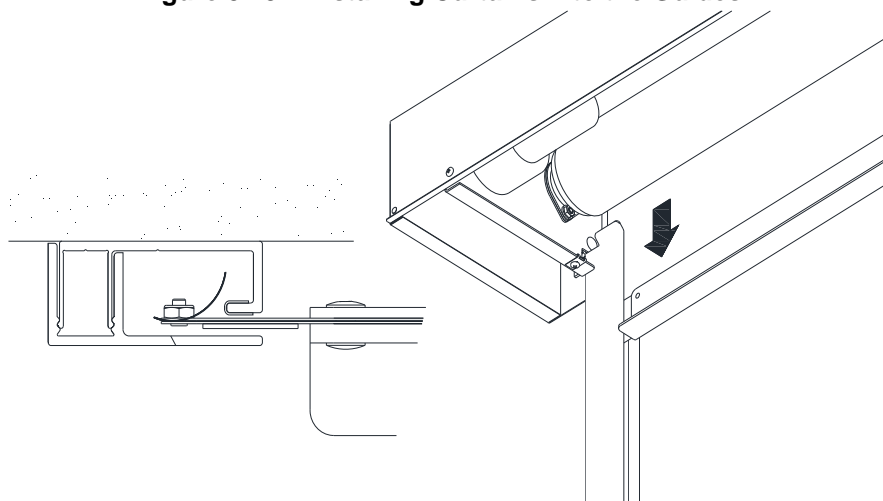

Figure 5.18 – Snap Direction



19. Remove the shipping bands and gently lower the curtain. Ensure the Bottom Bar and Edge Retention Bands thread into the Guides as shown.

Figure 5.19 – Installing Curtains into the Guides



20. Ensure the curtain moves freely throughout the Guides by lifting via the handle and letting the door drop closed.

Section 5 - Installation

21. Locate the input wiring which is attached to the Control Box. The input wiring includes:
 - (2) Wires [BLACK and WHITE] to be attached to 115 VAC
 - (2) Wires [PURPLE and GREY] to be connected to Alarm ConnectionRefer to the provided Operator Owner's Manual for more information.
22. Locate the pre-cut knockouts in the hood where the wiring will exit the Headbox. Remove the knockouts and install the preferred cord grip or conduit adapter. Route the wires through the hood as shown.
23. Make sure to pull the wiring tight or secure with the provided cable ties. Loose or excess wire left within the Hood could get caught in the spring assembly during operation.

Figure 5.23 – Input Wiring

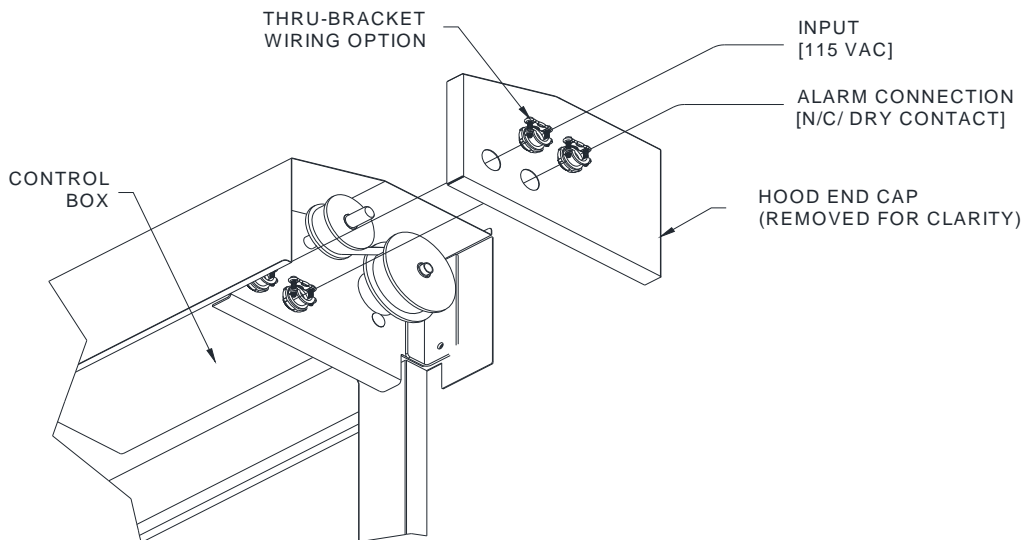

24. To install the Hood Cover, first attach the Upper Limit switches by connecting wiring harness located on the Hood Cover to the corresponding harness on the Headbox Assembly.
25. Hook the open hem on the Hood Cover over the flange on the Hood, and then install the #10 fasteners as shown.

Figure 5.25 – Installing Hood Cover

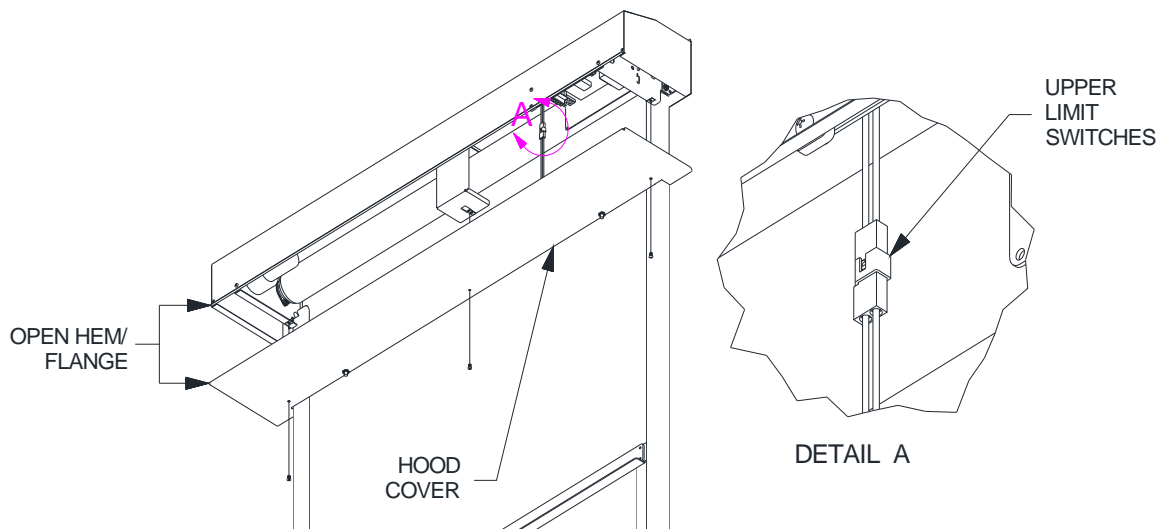

Section 5 - Installation

26. An Installation Clip is provided to hold the door in the Open position without power. Locate the Installation Clip. Remove the center #10 Hood Cover fastener. Manually lift the curtain into the Open position. Position the Installation Clip as shown and reinstall the Hood Cover Fastener.

Note: The Installation Clip should remain in place until operational turnover. The battery should be disconnected until permanent power is established to prevent battery consumption.

Figure 5.26 – Holding Door in Open Position without Power

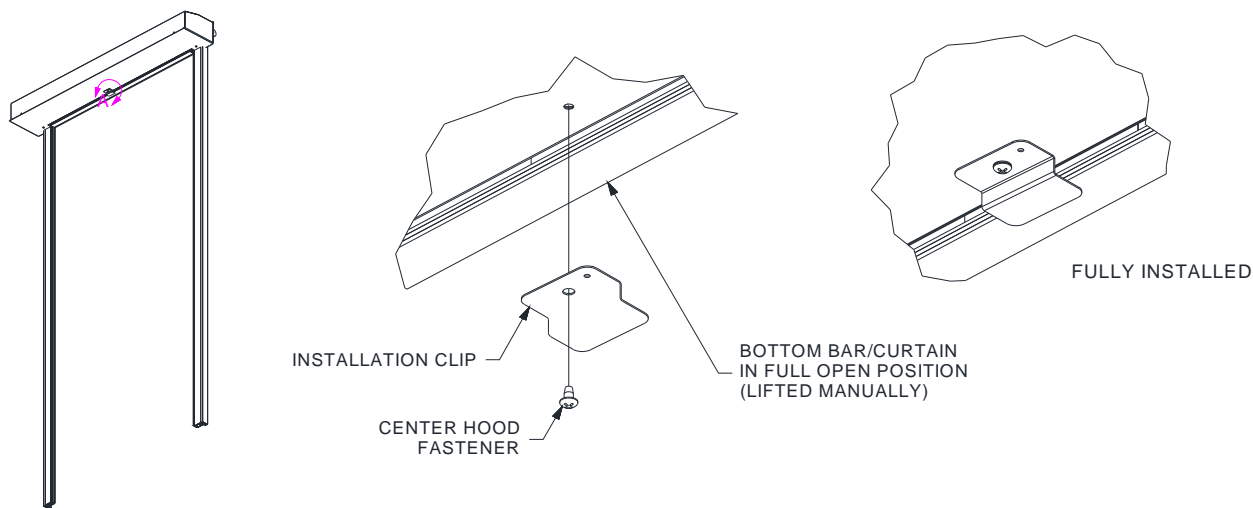

27. The Door can now be wired according to the provided Wiring Diagram. Refer to the provided Motor Owner's Manual.

28. Operation Testing (once door is wired):

1. Ensure the system is in "Alarm Mode" and turn on the power to the unit. The door should remain in the closed position.

2. Clear the "alarm mode". The door should return to the open position.

Note: The door may perform a few abbreviated "up/down" cycles near the upper limit the first time it reaches the full open position. The motor is calibrating the force required to hold the unit open.

3. Return the system to "Alarm Mode". The door should close.

4. Press the curtain mounted switch labeled "PUSH". The door should return to the full open position, pause for approximately 10 seconds and then reclose.

5. Reconfirm manual operation by lifting the door using the handle and then releasing. Door should reclose upon release.

29. After commissioning, re-install the Installation Clip to retain the curtain in the headbox until final inspection prior to turnover. Disconnect the battery to prevent battery usage prior to turnover.

30. When ready for turnover, remove the installation clip and reconnect the battery to the control panel.

Section 5 - Installation

Repairing Small Holes or Tears in Curtain:

In the event of a small hole or tear in the curtain, the curtain can be repaired in the field using a Curtain Repair Kit. The Curtain Repair Kit includes a 2" wide High-Temperature Tape to patch the curtain.

1. Inspect the damaged area:
 - a. If the tear is longer than 6" in length, or if the damage resulted in material being removed from the curtain (such that it would require a patch), Contact Service on how to proceed.
 - b. If not, Contact the Service Department to order the *SmokeShield: Elevator Curtain Repair Kit*.
2. The tape must be positioned so that it covers the entire puncture and exceeds it by approximately 1" on all sides. It may be helpful to faintly mark the curtain to help locate the tape when applying. Removing the tape once it is applied to the curtain is very difficult and to be avoided if possible as it may further damage the curtain.
3. Reposition and flatten the curtain so the edges of the tear/hole are touching, eliminating or minimizing gaps as much as possible. Place the tape of the tear/hole.
4. To ensure that the adhesive surface of the tape is not exposed on the opposing side of the curtain, place an additional piece of tape on the opposite side of the curtain to cover it, as any exposed adhesive surface may cause damage when coiled.

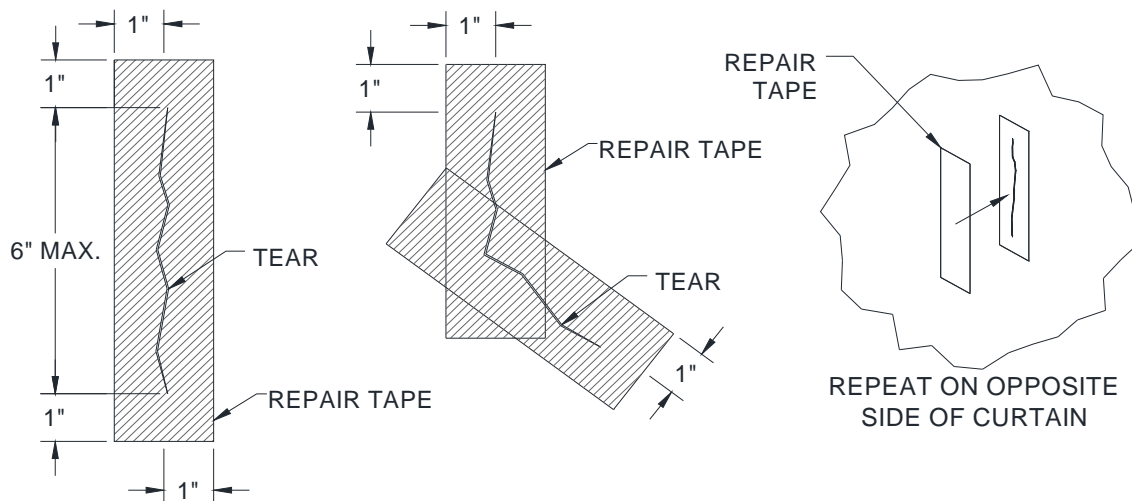

Section 6 - Maintenance Schedule

▪ **Maintenance Schedule:**

This product requires annual inspection and drop testing per NFPA 90.

Note: If any of the following problems exist, **do not** operate the door until repaired.

Component	What to look for and how often the components must be inspected:	Monthly	Annually	What to do if problem exists:
Door operation	Does the door fully close upon alarm?		X	Clear any debris from guide gap or opening; retry. Contact Service if issue persists.
	Can the door be easily lifted using the handle?		X	Ensure Spring Assembly is functioning properly. Contact Service for details.
	Does the door open when the "Push" switch is activated?		X	Check that switch is connected properly in Control Box. Check for breaks or fraying in wire. Contact Service.
	Is Bottom Bar level?		X	Check that the curtain is coiling smoothly and evenly. Check for any debris, wrinkles or other issues in the coil. Ensure Hood/Guides are level/plumb.
Curtain & Bottom Bar	Are there any tears, holes or noticeably worn areas visible on the curtain?		X	If the puncture is within the size limitations, utilize Repair Kit. If not, contact Service.
	Are the curtain graphics worn or illegible?		X	Contact Service about replacing curtain; provide a photo.
	Is the handle visibly worn, frayed, or no longer fixed to the curtain in the upright and easily accessed position?		X	Contact Service; provide a photo.
	Is the switch or wiring not fully adhered to the curtain?		X	Contact Service about replacing switch/curtain.
Guides	Is guide gap dimension correct?	X		Check if either of the other "check" items on this list are the cause. Contact Service.
	Are any of the guide parts bent or damaged?	X		Contact Service about replacing Guides.
	Are the Guides fully snapped together?	X		If Guides are accessible, revisit steps 18-20. Otherwise contact Service.

Appendix A – Leakage Rating Information

Leakage Rating Information:

Note: The following information was taken from: <http://www.ul.com/global/eng/pages/> under "Certifications".

- Leakage rated assemblies — SmokeShield Elevator Curtain file R25122.

Table A.1 Leakage Rating Information

Test Pressure (in. of WC)	Air Temp, °F	Leakage, (cfm/ft ²)
0.05	Ambient	0.74
0.1	Ambient	1.2
0.2	Ambient	2.31
0.3	Ambient	6.82
0.05	400	0.43
0.1	400	1.16
0.2	400	1.89
0.3	400	7.54